

# BX行星式減速機 標準型



BX	—	90	—	L1	—	10	—	K	—	F3
機型		框號		段數		減速比		出力軸		入力端
BX		42 60 90 115 142		L1 L2 L3		3~10 15~100 125~		鍵軸:K 光軸:S		F1 F2 F3 F4 F5 F6 F7

# 輸出軸之容許徑向力

\*容許徑向力:垂直於軸心的力量

\*容許軸向力:平行於軸心的力量

容許徑、軸向力與減速機的出力軸轉速及施力點的距離相關。轉速越快，容許徑向力會降低。負載的距離越遠，容許的徑向力也隨之降低。

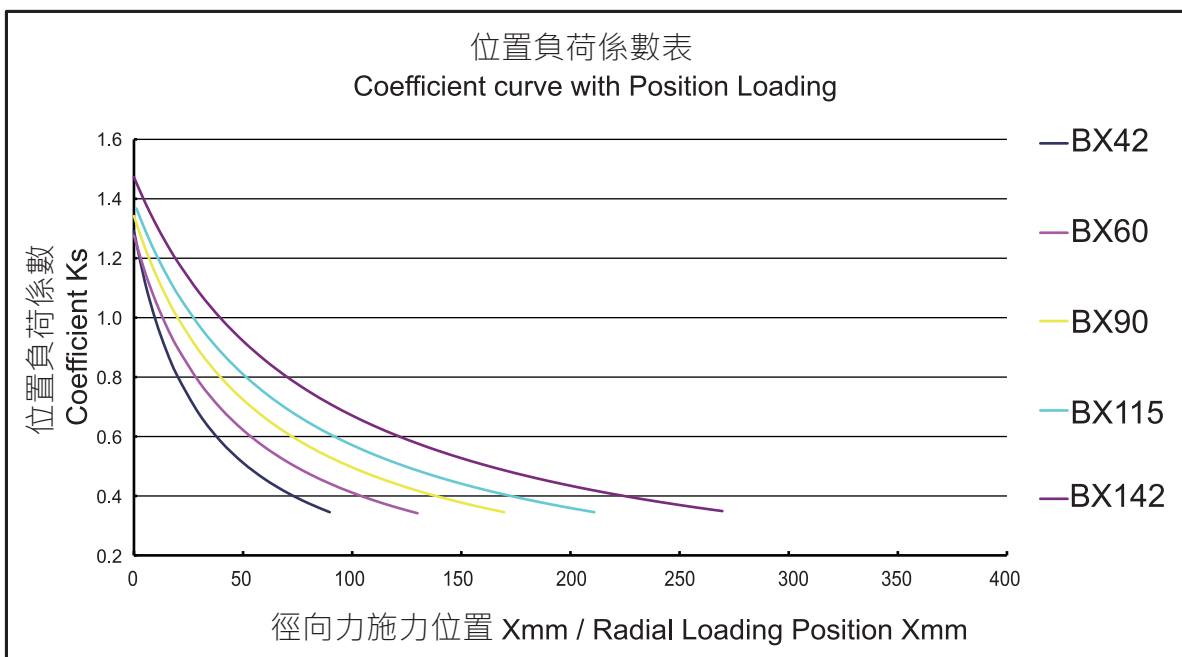
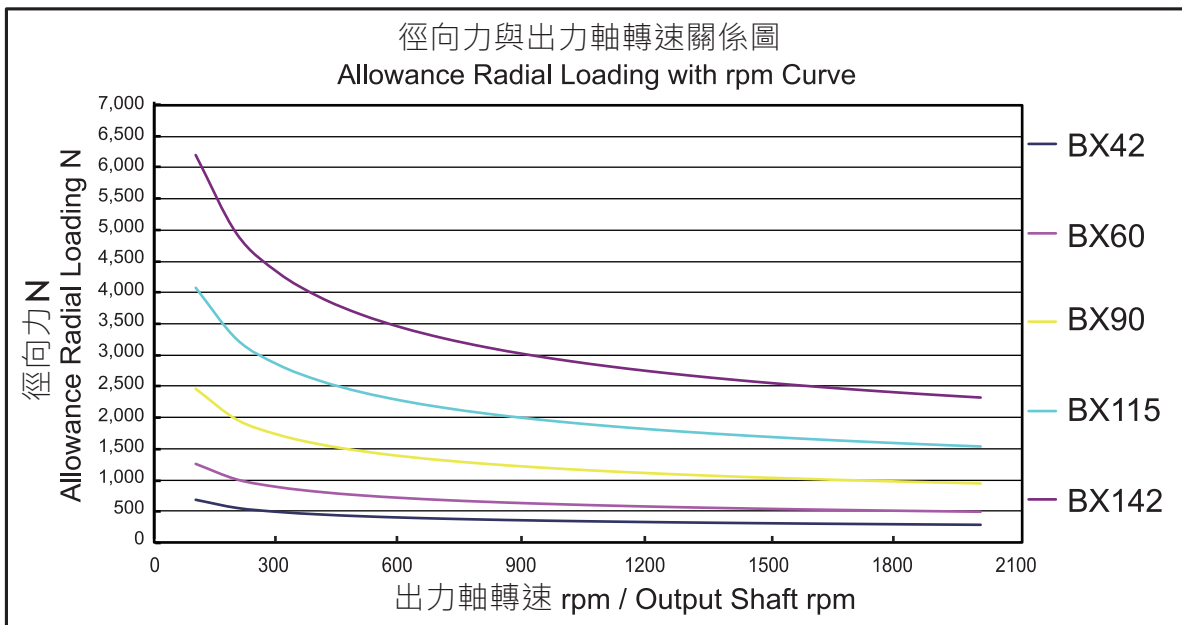
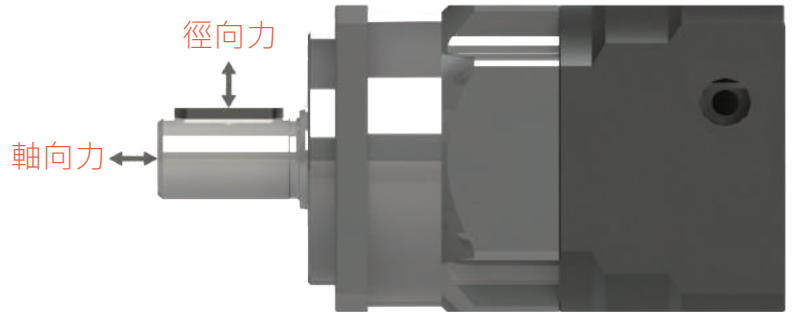

# 減速機性能資料

規格 Specifications	單位 Unit	段數 Stage	減速比 Ratio	BX42	BX60	BX90	BX115	BX142	
額定輸出力矩 $T_{2N}$ Nominal Output Torque	Nm	L1	3	15.0	42	125	238	571	
			4	15.0	38	122	250	599	
			5	16.0	40	150	256	630	
			6	13.5	34	108	235	610	
			7	12.5	34	130	265	538	
			8	13.0	33	130	240	506	
			9	12.5	31	128	235	500	
		L2	10	12.0	31	128	235	496	
			15	14.1	36	126	238	571	
			20	12.0	38	122	285	599	
			25	14.0	36	157	300	630	
			30	13.2	36	136	288	591	
			35	11.9	34	130	265	538	
			40	12.9	38	122	258	599	
			50	10.8	36	157	300	635	
			60	13.2	34	108	229	533	
			70	11.9	34	110	225	538	
			80	12.9	33	103	212	506	
90	12.0	31	102	220	500				
100	12.0	31	128	235	496				
急停力矩 Emergency Stop Torque	Nm	L1,L2	3~100	3倍額定輸出力矩 3times Nominal Output Torque				2.5倍額定輸出力矩 2.5times Nominal Output Torque	
額定輸入轉速 $n_{1N}$ Nominal Input Speed	rpm	L1,L2	3~100	3,000	3,000	3,000	3,000	2,500	
最大輸入轉速 Max. Input Speed	rpm	L1,L2	3~100	6,000	6,000	6,000	6,000	5,000	
標準背隙 BackLash	arcmin	L1	3~10	$\leq 7$	$\leq 7$	$\leq 7$	$\leq 7$	$\leq 7$	
		L2	15~100	$\leq 10$	$\leq 10$	$\leq 10$	$\leq 10$	$\leq 10$	
扭轉剛性 Torsional Rigidity	Nm/arcmin	L1	3~10	2.13	4.3	11	32	65	
		L2	15~100	1.28	2.6	6.5	19	39	
最大容許徑向力 $F_{2rB}$ Max. Radial Load	N	L1,L2	3~100	700	1,400	2,800	5,000	7,500	
最大容許軸向力 $F_{2aB}$ Max. Axial Load	N	L1,L2	3~100	350	700	1,400	2,500	3,750	
使用壽命 Life	hrs	L1,L2	3~100	20,000					
使用溫度 Operating Temperature	°C	L1,L2	3~100	-10°C~+90°C					
潤滑 Lubrication		L1,L2	3~100	合成潤滑油脂 Lithium Complex Synthetic					
安裝方向 Mounting Position		L1,L2	3~100	任意方向 Any Direction					
噪音值 Running Noise	dB(A)	L1,L2	3~100	$\leq 63$	$\leq 65$	$\leq 65$	$\leq 68$	$\leq 70$	
效率 $\eta$ Efficiency	%	L1	3~10	$\geq 97\%$					
		L2	15~100	$\geq 94\%$					
重量 Weight	kg	L1	3~10	0.43	1.21	3.7	7.4	13.2	
		L2	15~100	0.70	1.70	4.1/5.2	8.2/10	15.0/19.0	
防護 Protection Level		L1,L2	3~100	IP65					

# 減速機轉動慣量

BX轉動慣量總表 Moment of Inertia Table																					
單位Unit	kg.cm <sup>2</sup>	型號 Model																			
段數 Stage	減速比 Ratio	BX42	BX60		BX90		BX115		BX142												
		伺服馬達軸直徑 Servomotor Shaft Diameter																			
		≤ φ 8	≤ φ 8	≤ φ 14	≤ φ 14	φ 19	φ 24	≤ φ 19	≤ φ 24	φ 24	φ 35	φ 42									
單段 1-stage	3	0.02		0.08		0.53	0.48		1.63	4.49	8.20	7.82									
	4	0.01		0.08		0.48	0.42		1.43	2.97	6.68	6.30									
	5					0.46	0.40		1.36	2.68	6.39	6.00									
	6			0.07								1.30	2.55	6.26	5.88						
	7											1.30	2.51	6.22	5.84						
	8											0.44	0.38					2.48	6.19	5.81	
	9																	1.28	2.47	6.18	5.80
	10																		2.46	6.17	5.79
雙段 2-stages	15																	0.01	0.01	0.07	0.07
	20	0.44	0.39	0.44	1.37	1.37	6.25	5.87													
	25	0.43	0.38	0.43	1.34	1.34	6.16	5.78													
	30																				
	35								0.44	0.39	0.44	1.37	1.37	6.25	5.87						
	40	0.43	0.38	0.43	1.34	1.34	6.16	5.78													
	50																				
	60																				
	70																				
	80																				
	90																				
	100																				

1. 減速比：i = 輸入轉速/輸出轉速。
2. 背隙值：為在2%額定輸出扭矩下測試所得之數據。
3. 最大徑向力及最大軸向力：施力於出力軸中心位置，轉速100rpm，條件下所測得之數據。
4. 運轉負載週期<60%狀況下，平均使用壽命如列表數據值；低至正常值的50%以下。
5. 噪音值：距離1公尺，空載運轉，額定輸入轉速，條件下所測得之數據。

# 減速機一段尺寸圖(L1)

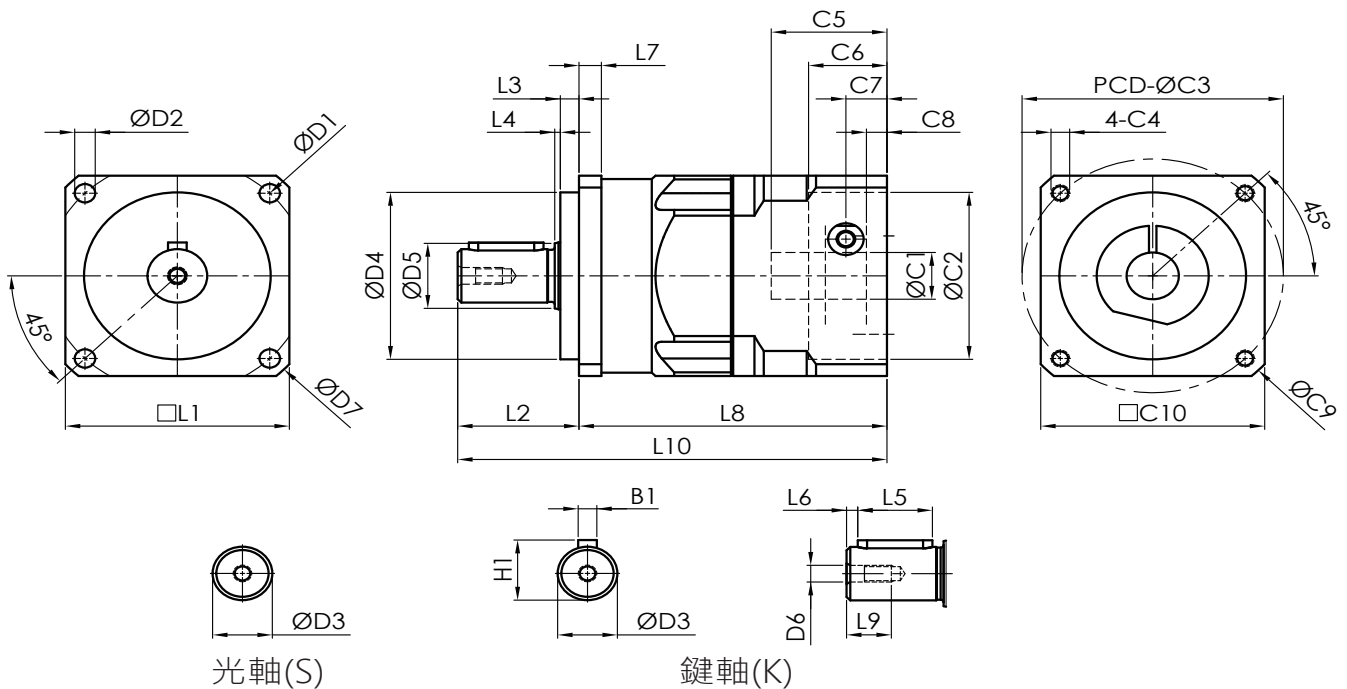

型號	BX42	BX60	BX90	BX115	BX142
D1	50	70	100	130	165
D2	3.5	5.5	6.8	9	11
D3 <sub>h7</sub>	13	16	22	32	40
D4 <sub>h7</sub>	35	50	80	110	130
D5	13.6	19.5	29.2	34.2	53.9
D6	M4x0.7P	M5xP0.8	M6xP1.0	M8xP1.25	M16xP2.0
D7	56	80	116	152	190
L1	42	60	90	115	142
L2	25	32.5	46.5	64	92
L3	5	5	5	10	10
L4	1	1.5	1.5	2	3
L5	15	20	30	40	65
L6	2	3	3	5	5
L7	5	6	8	16	18
L8	60	82.5	107	140	171.5
L9	10	12	15	28	36
L10	85	115	153.5	204	263.5
*C1 <sub>H7</sub>	8	14	19	24	35
*C2 <sub>H7</sub>	30	50	70	110	114.3
*C3	46	70	90	145	200
*C4	M4x0.7P	M5xP0.8	M6xP1.0	M8xP1.25	M12xP1.75
*C5	26	31	43.5	67	83
*C6	17	21	30	18	20
*C7	8.5	11	14	31	39
*C8	4	5.5	7	22	28
*C9	56	80	116	160	230
*C10	42.5	60	90	120	176
B1	5	5	6	10	12
H1	15	18	24.5	35	43

\*C1~C10為伺服馬達尺寸，會依照各大廠牌伺服馬達尺寸而變。

# 減速機二段尺寸圖(L2)

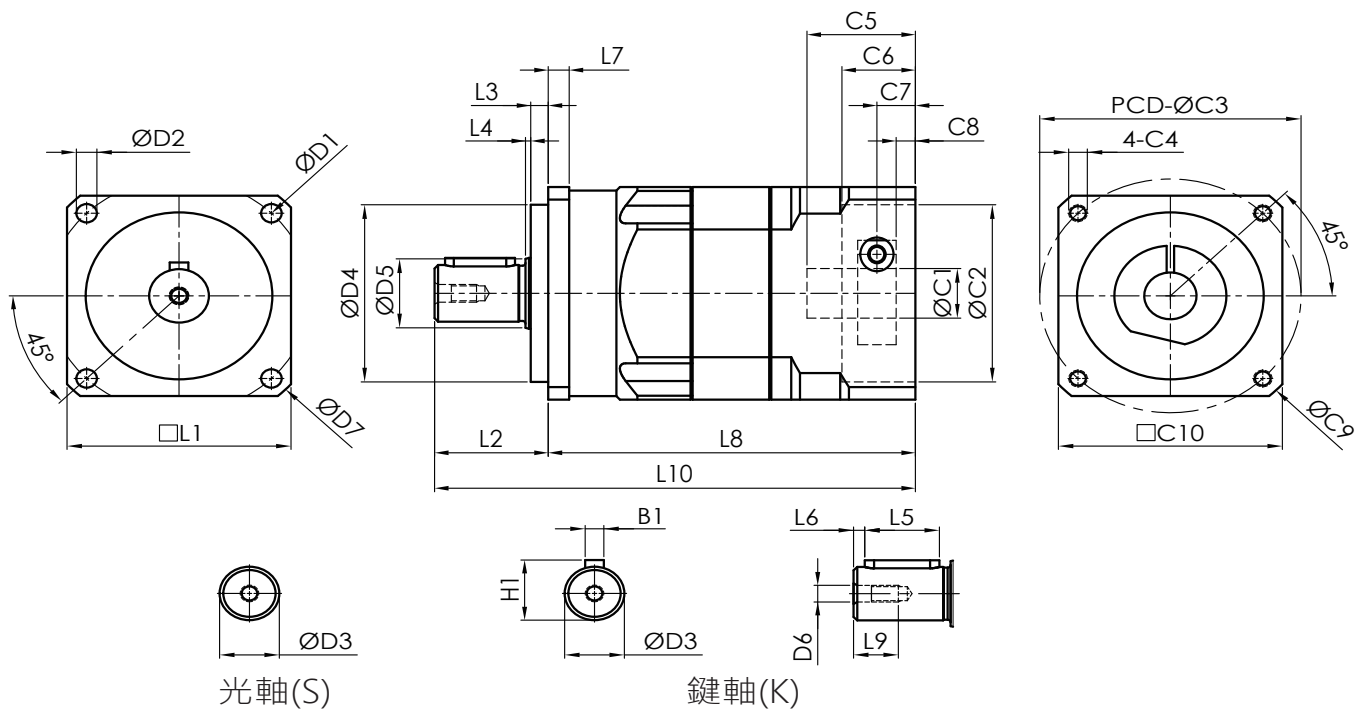

型號	BX42	BX60	BX90	BX115	BX142
D1	50	70	100	130	165
D2	3.5	5.5	6.8	9	11
D3 <sub>h7</sub>	13	16	22	32	40
D4 <sub>h7</sub>	35	50	80	110	130
D5	13.6	19.5	29.2	34.2	53.9
D6	M4x0.7P	M5xP0.8	M6xP1.0	M8xP1.25	M16xP2.0
D7	56	80	116	152	190
L1	42	60	90	115	142
L2	25	32.5	46.5	64	92
L3	5	5	5	10	10
L4	1	1.5	1.5	2	3
L5	15	20	30	40	65
L6	2	3	3	5	5
L7	5	6	8	16	18
L8	77	105	138.5	176.5	218
L9	10	12	15	28	36
L10	102	137.5	185	240.5	310
*C1 <sub>H7</sub>	8	14	19	24	35
*C2 <sub>H7</sub>	30	50	70	110	114.3
*C3	46	70	90	145	200
*C4	M4x0.7P	M5xP0.8	M6xP1.0	M8xP1.25	M12xP1.75
*C5	26	31	43.5	67	83
*C6	17	21	30	18	20
*C7	8.5	11	14	31	39
*C8	4	5.5	7	22	28
*C9	56	80	116	160	230
*C10	42.5	60	90	120	176
B1	5	5	6	10	12
H1	15	18	24.5	35	43

\*C1~C10為伺服馬達尺寸，會依照各大廠牌伺服馬達尺寸而變。